

<b>PM 165 SINGLE STRAND</b>		
IRON / HCFEcr / FeNi / Ni Alloy / FeSi	82 tons / hr	75 metric ton /hr
Ni Matte / Cu matte / FeMn / SiMn		
COOLING TIME	5.5 MINUTES	5.5 MINUTES
MOULDS	DOUBLE CAVITY	DOUBLE CAVITY
TOTAL INGOT WEIGHT	120 LBS TOTAL	54.4 kg TOTAL

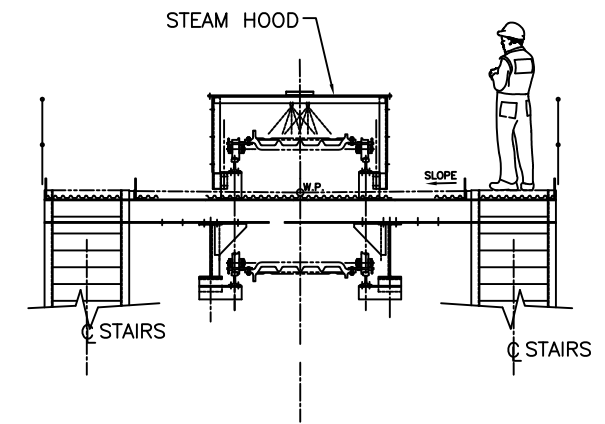
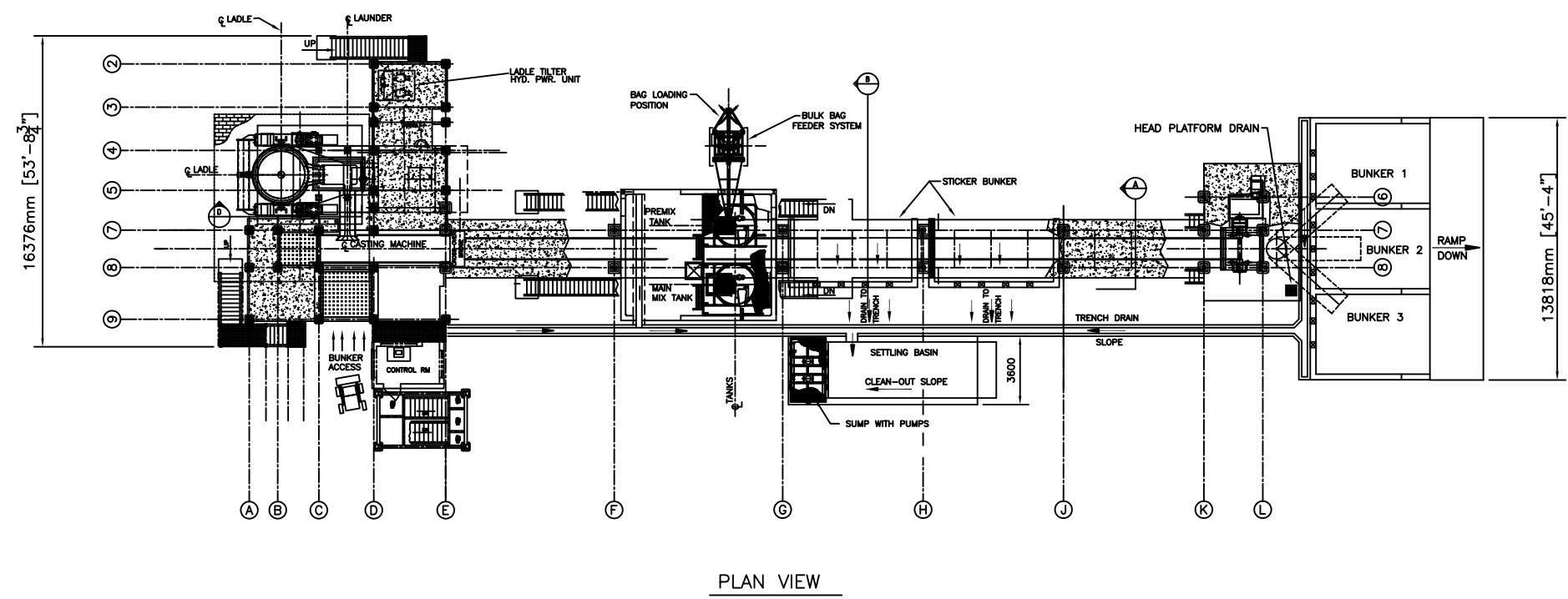
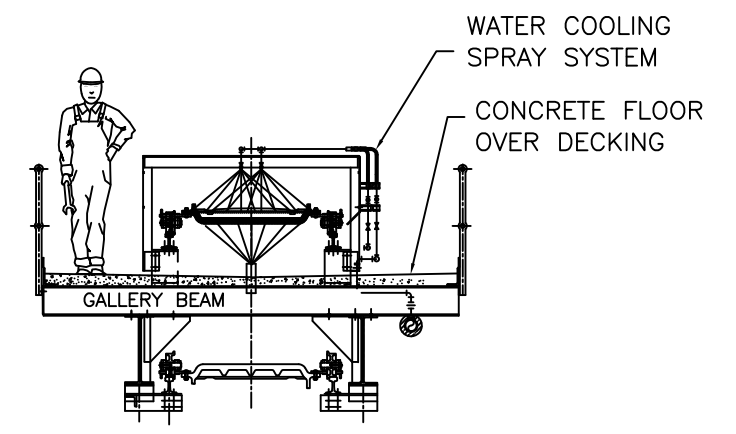
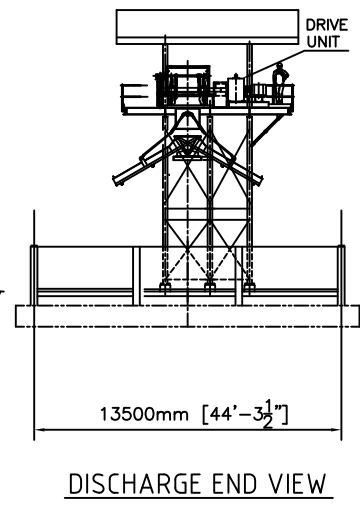
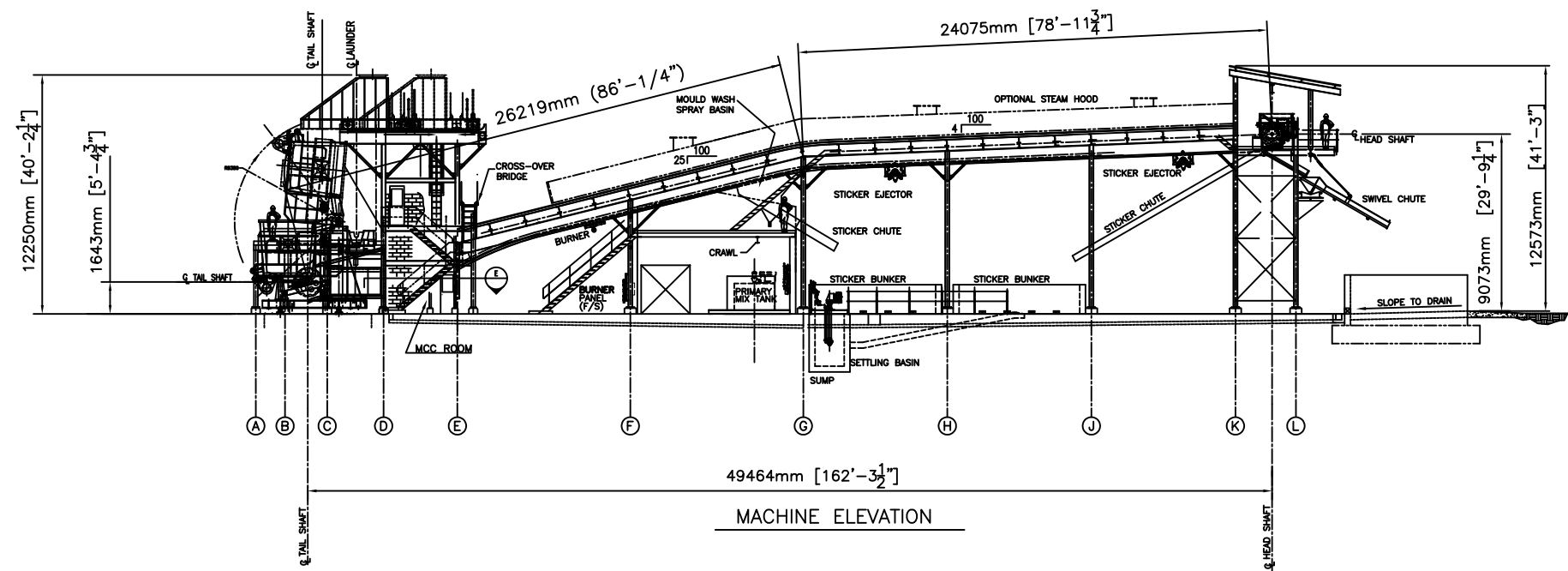

© 2013 This drawing is the property of Economy Industrial, Ambridge, PA, and is provided for the use of its clients only for the purpose intended. Unauthorized reproduction or distribution to third parties without the consent of Economy Industrial is a violation of U.S. and International Copyright laws.

**ECONOMY INDUSTRIAL**  
ENGINEERS AND CONTRACTORS AMBRIDGE, PA 15003 U.S.A.  
MODEL PM165SS INGOT CASTING MACHINE

GENERAL ARRANGEMENT

APPROVED	REVIEWED	CHECKED	DRAWN BY	DATE	SCALE	DRAWING No. PM-165	REV.
----------	----------	---------	----------	------	-------	--------------------	------

E.I. REF. No.