

PM 105 SINGLE STRAND

IRON / HCFer / FeNi / Ni Alloy / FeSi	50 tons / hr	45 metric ton/hr
Ni Matte / Cu matte / FeMn / SiMn		
COOLING TIME	5.5 MINUTES	5.5 MINUTES
MOULDS	DOUBLE CAVITY	DOUBLE CAVITY
TOTAL INGOT WEIGHT	120 LBS TOTAL	54.4 kg TOTAL

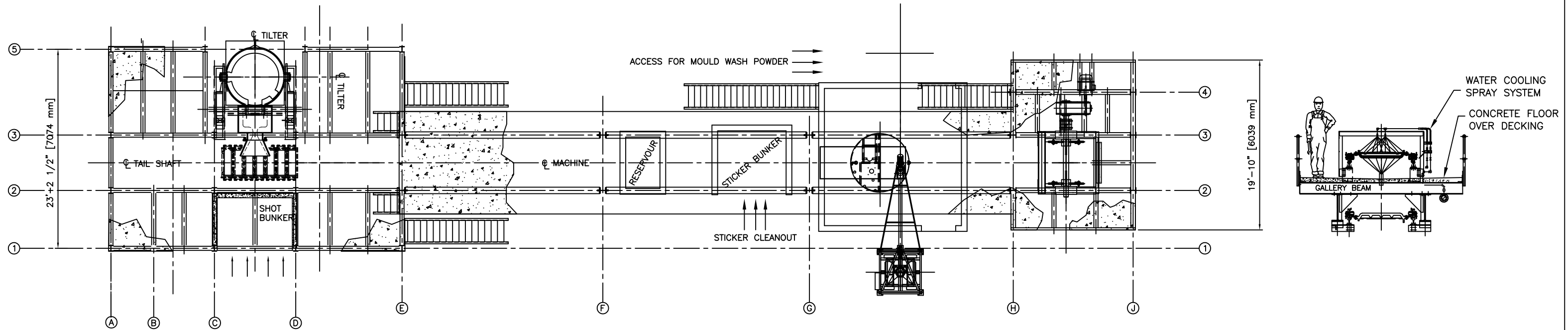

PLAN VIEW

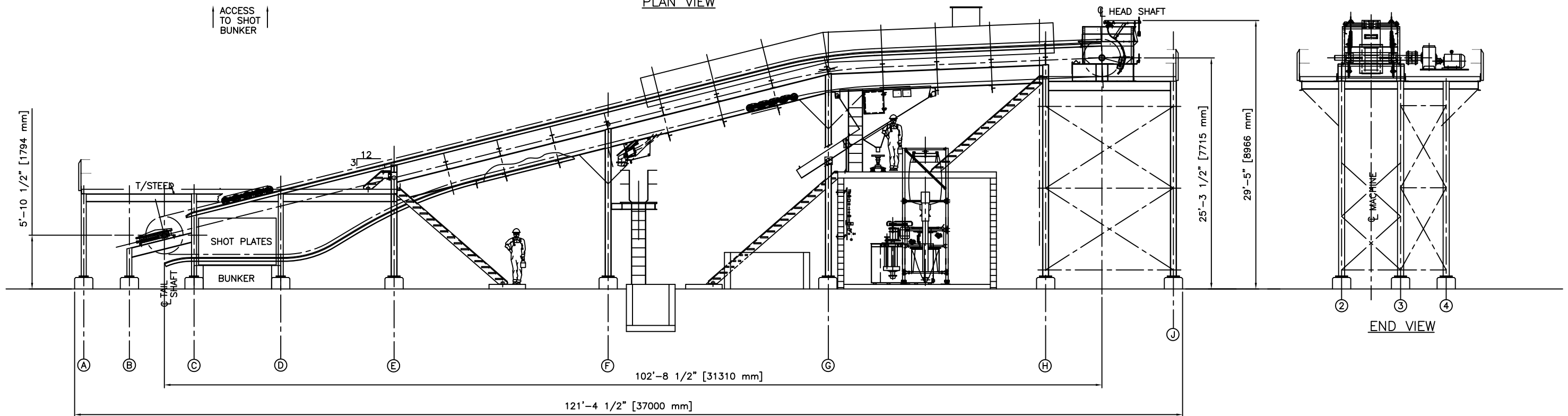

ELEVATION

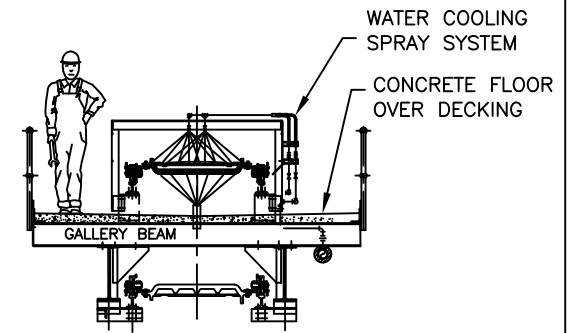

END VIEW

© This drawing is the property of Economy Industrial, Ambridge, PA, and is provided for the use of its clients only for the purpose intended. Unauthorized reproduction or distribution to third parties without the consent of Economy Industrial is a violation of U.S. and International Copyright laws.

ECONOMY INDUSTRIAL
 ENGINEERS AND CONTRACTORS AMBRIDGE, PA 15003 U.S.A.
 MODEL PM105SS INGOT CASTING MACHINE

E.I. REF. No.	APPROVED	REVIEWED	CHECKED	DRAWN BY	DATE	SCALE	DRAWING No. PM-105	REV.
---------------	----------	----------	---------	----------	------	-------	--------------------	------

GENERAL ARRANGEMENT