

MC 40		
VOLUME / hr	49 cu ft/hr	1.39 cu meter/hr
IRON / TIN / ZINC (tons/hr)	12 tons / hr	10.88 metric ton/hr
COPPER / NICKEL ALLOY (tons/hr)	15 tons	13.60 metric ton
COOLING TIME	5.5 MINUTES	5.5 MINUTES
MOULDS	DOUBLE CAVITY	DOUBLE CAVITY
TOTAL INGOT WEIGHT	50 LBS TOTAL	22.7 kg TOTAL

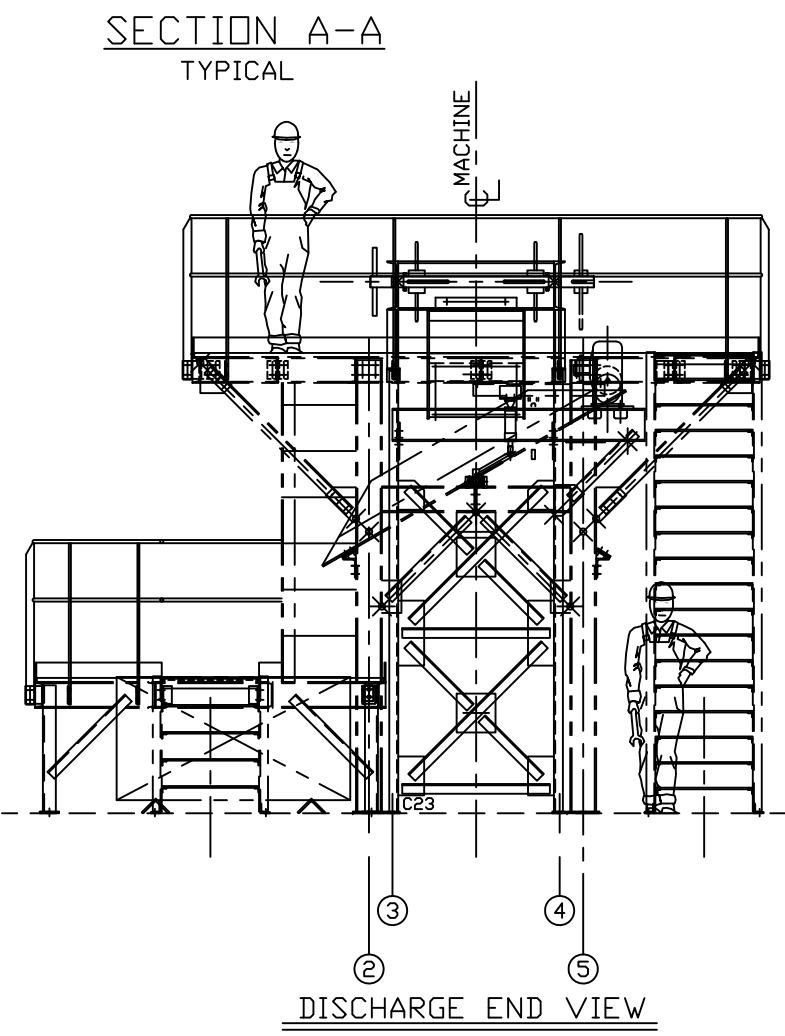
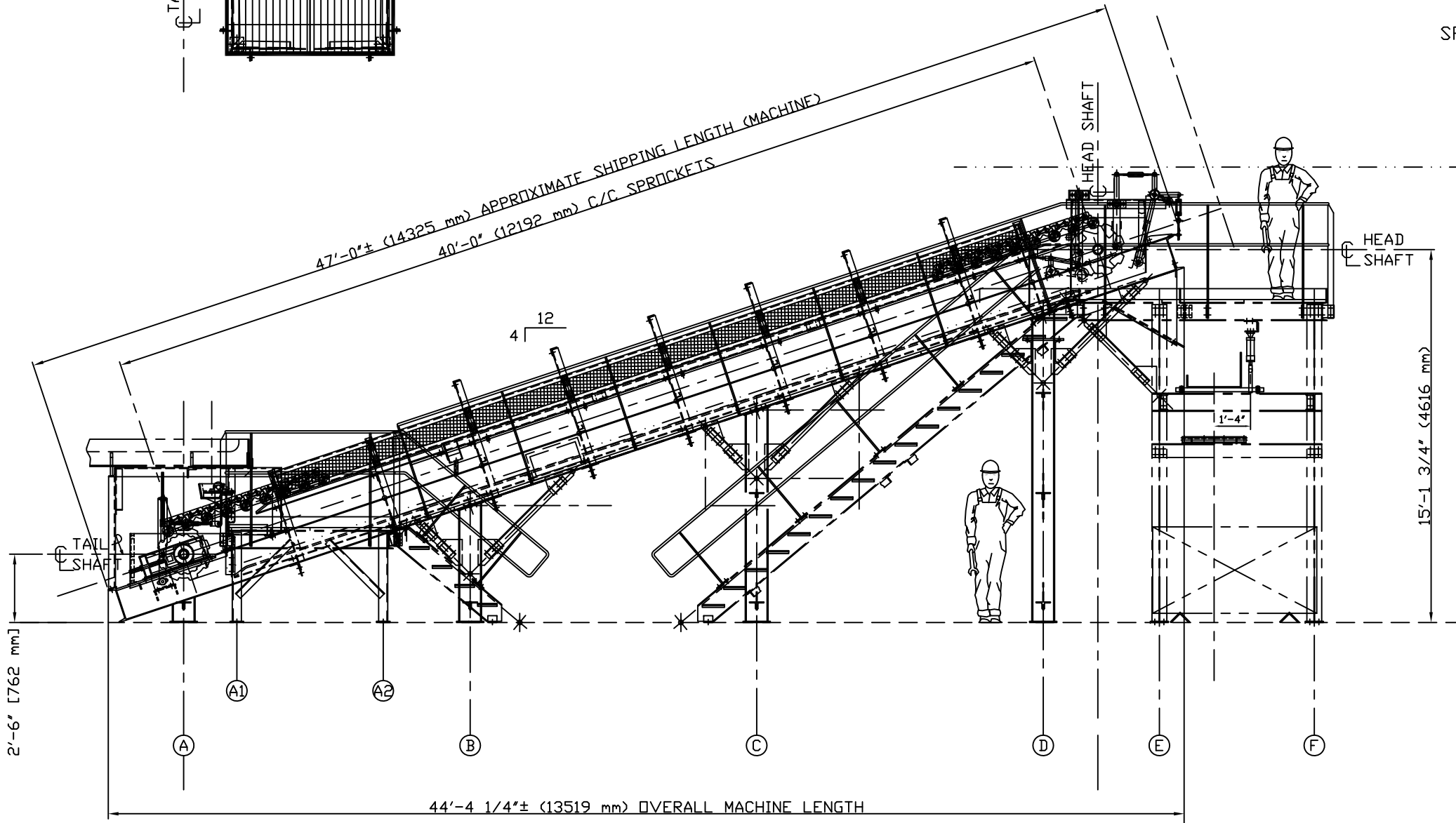
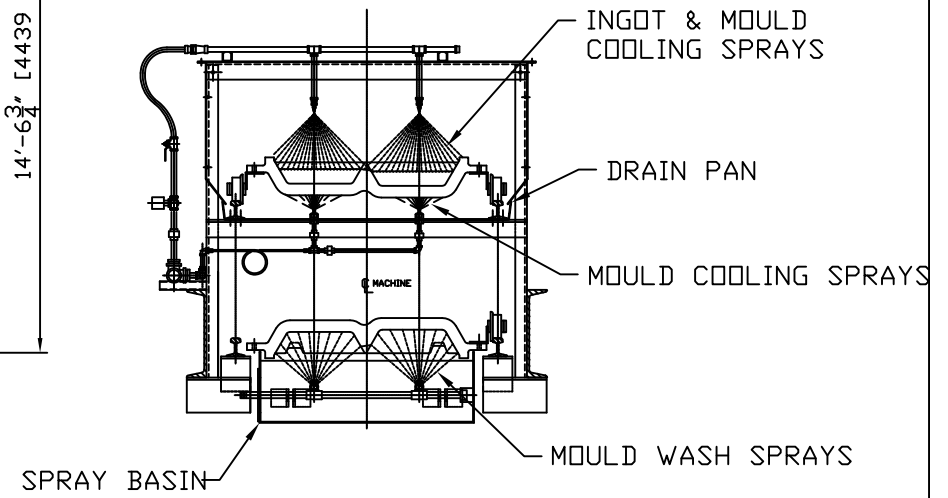

© This drawing is the property of Economy Industrial Corporation, Ambridge, PA, U.S.A. and is provided for the use of its clients only for the purpose intended. Unauthorized reproduction or distribution to third parties without the consent of Economy Industrial Corporation is a violation of U.S. and International Copyright laws.

ECONOMY INDUSTRIAL CORPORATION
 ENGINEERS AND CONTRACTORS AMBRIDGE, PA 15003 U.S.A.

MODEL MC-40SS CASTING MACHINE

APPROVED	REVIEWED	CHECKED	DRAWN BY	DATE	SCALE	CLIENT DRAWING No.	REV
						MC-40	