

<b>MC 25</b>		
VOLUME / hr	33 cu ft/hr	0.93 cu meter/hr
IRON / TIN / ZINC (tons/hr)	8 tons / hr	7.26 metric ton/hr
COPPER / NICKEL ALLOY (tons/hr)	12 tons / hr	10.88 metric ton
COOLING TIME	5.5 MINUTES	5.5 MINUTES
MOULDS	DOUBLE CAVITY	DOUBLE CAVITY
TOTAL INGOT WEIGHT	35 LBS TOTAL	15.8 kg TOTAL

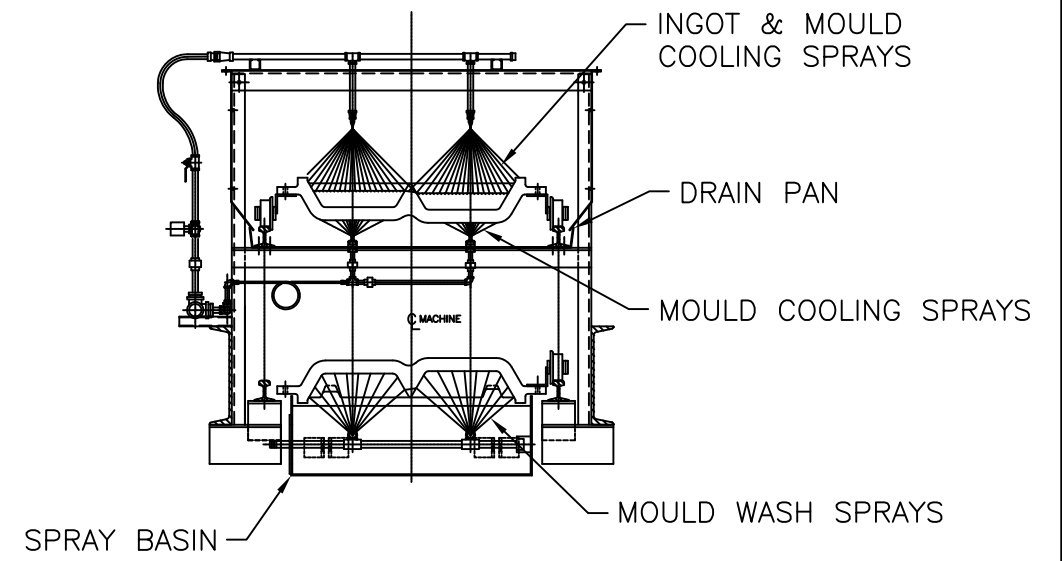

SECTION A-A  
TYPICAL

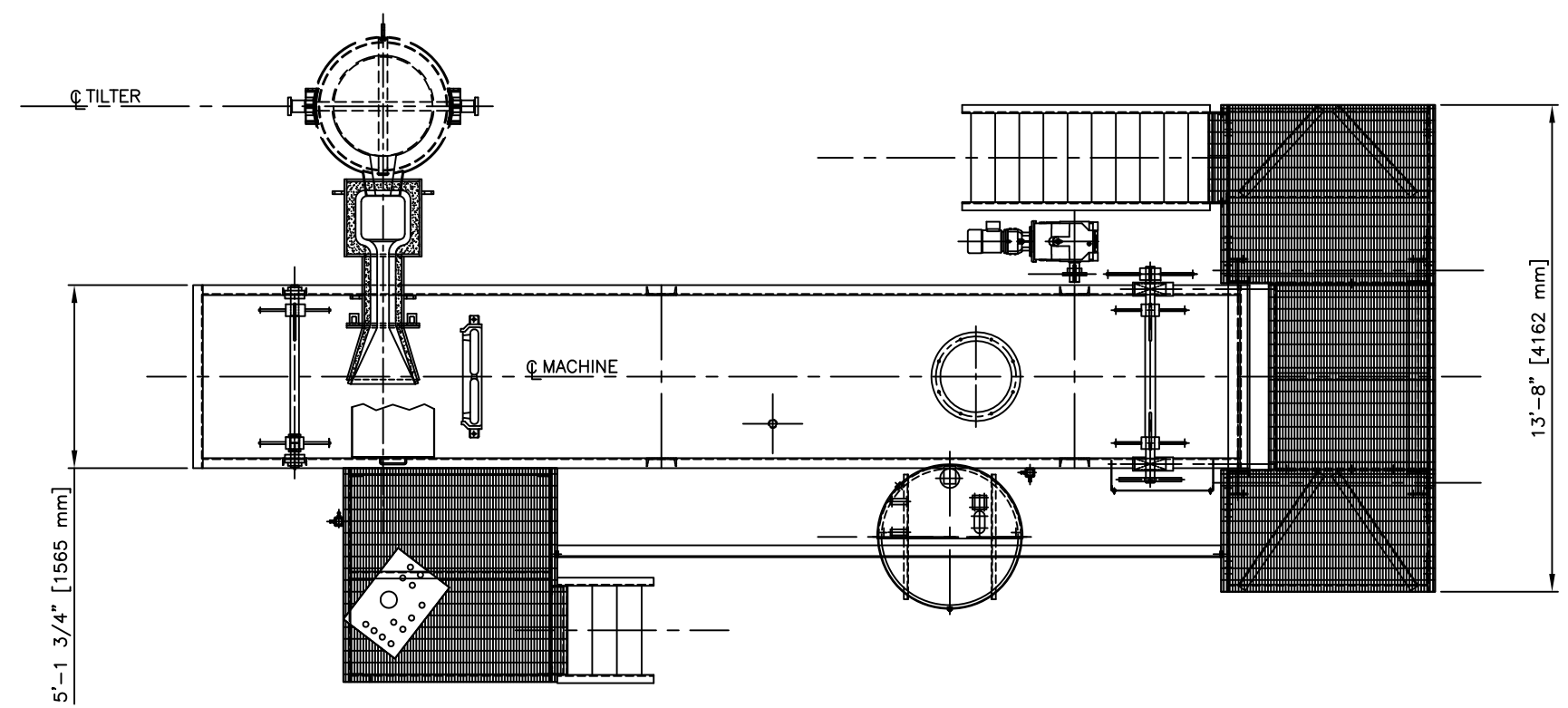
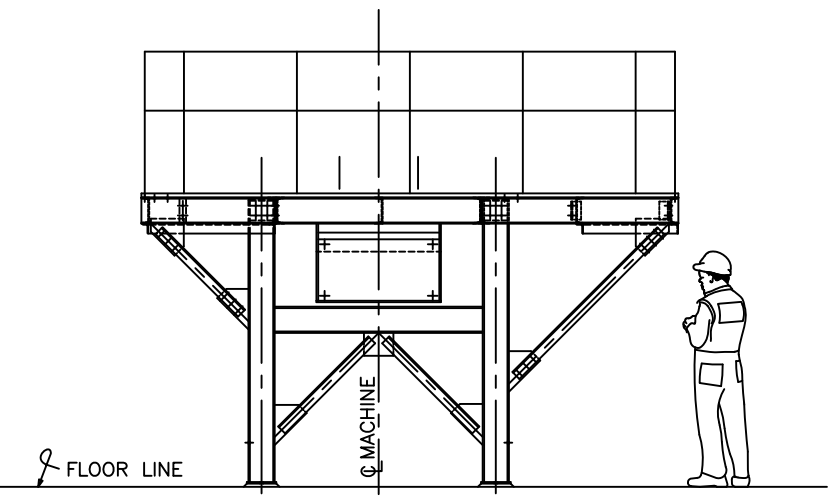
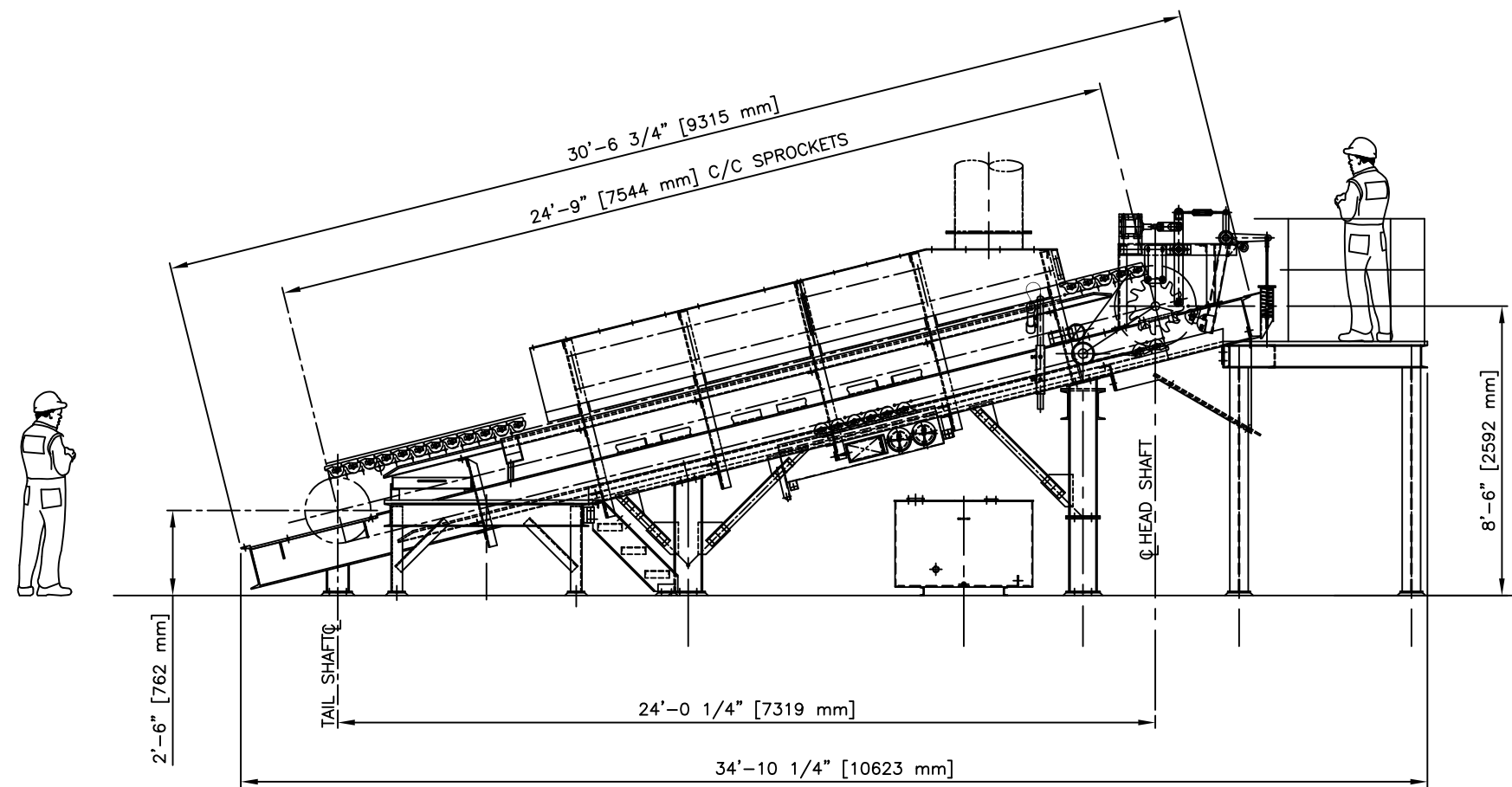

© This drawing is the property of Economy Industrial, Ambridge, PA, and is provided for the use of its clients only for the purpose intended. Unauthorized reproduction or distribution to third parties without the consent of Economy Industrial is a violation of U.S. and International Copyright laws.

**ECONOMY INDUSTRIAL**  
ENGINEERS AND CONTRACTORS AMBRIDGE, PA 15003 U.S.A.  
MODEL MC25SS INGOT CASTING MACHINE

E.I. REF. No.	APPROVED	REVIEWED	CHECKED	DRAWN BY	DATE	SCALE	DRAWING No. MC-25	REV.
---------------	----------	----------	---------	----------	------	-------	----------------------	------