

MC 15

VOLUME / hr	16 cu ft/hr	0.45 cu meter/hr
IRON / TIN / ZINC (tons/hr)	4 tons / hr	3.63 metric ton/hr
COPPER / NICKEL ALLOY (tons/hr)	5 tons /hr	4.54 metric ton
COOLING TIME	MINUTES	5.5 MINUTES
MOULDS	DOUBLE CAVITY	DOUBLE CAVITY
TOTAL INGOT WEIGHT	35 LBS TOTAL	15.8 kg TOTAL

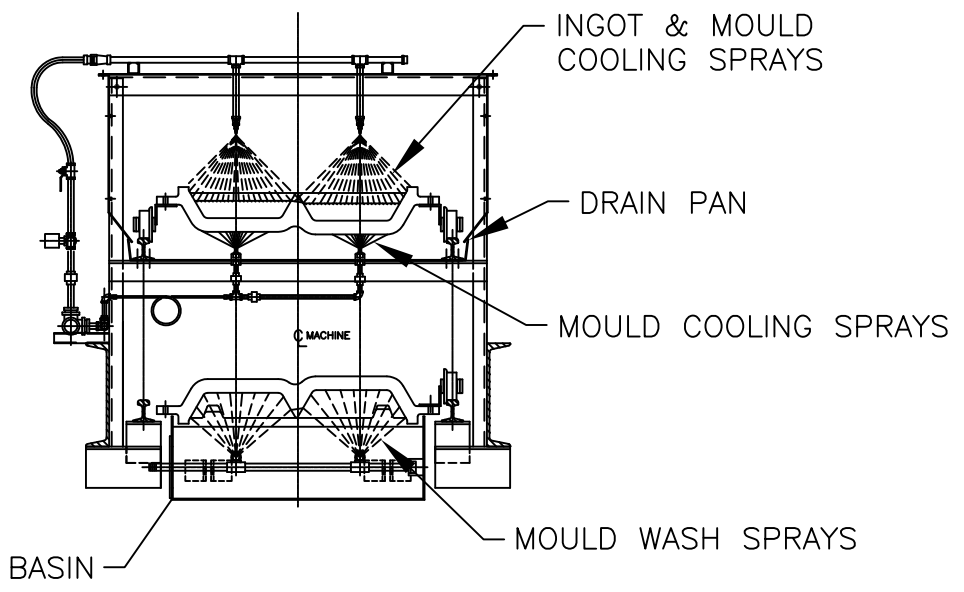
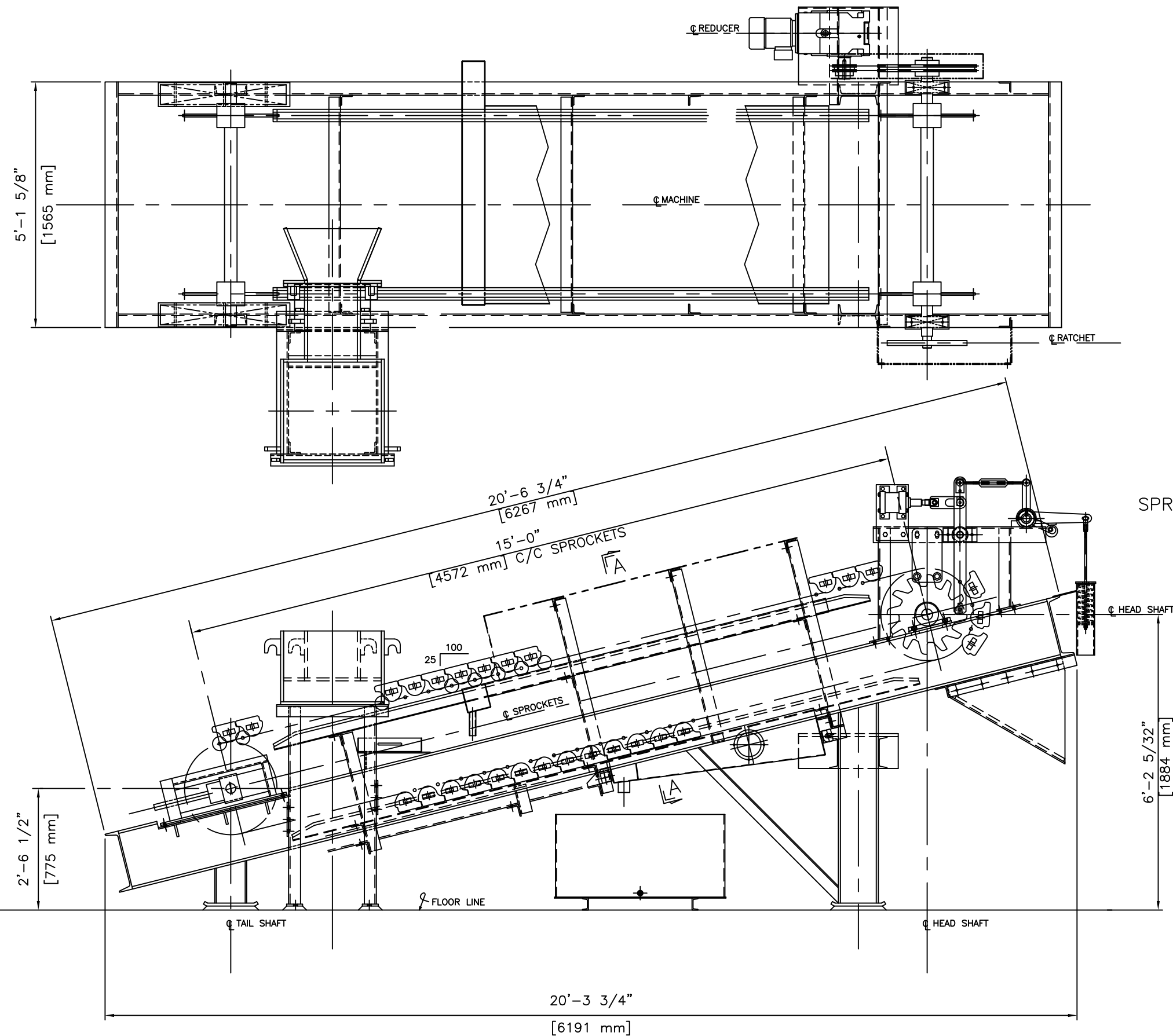

SECTION A-A
TYPICAL

© 2008 This drawing is the property of Economy Industrial Corp., Ambridge, PA, and is provided for the use of its clients only for the purpose intended. Unauthorized reproduction or distribution to third parties without the consent of Economy Industrial Corp. is a violation of U.S. and International Copyright laws.

ECONOMY INDUSTRIAL CORPORATION
ENGINEERS AND CONTRACTORS AMBRIDGE, PA 15003 U.S.A.
MODEL MC-15SS INGOT CASTING MACHINE

APPROVED	REVIEWED	CHECKED	DRAWN BY	DATE	SCALE	DRAWING No.	REV.
						MC-15	

E.I.C. REF. No.